

REV.	DESCRIPTION	DATE	APPROVED
------	-------------	------	----------

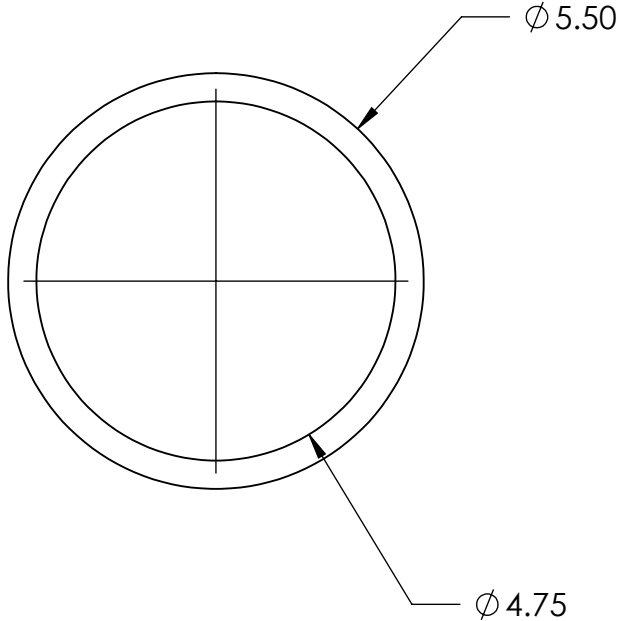
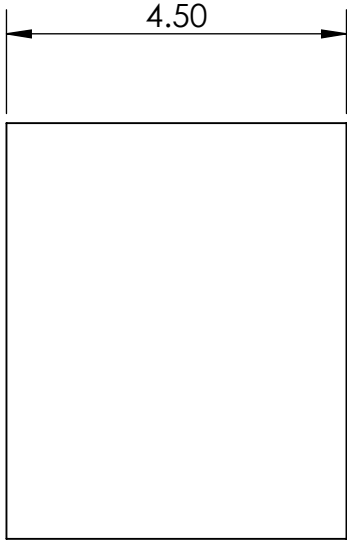

CONFIDENTIALITY NOTICE:

THIS INFORMATION IS OWNED BY FIBERFIN, INC. AND CONTAINS MATERIALS CONCERNING FIBERFIN, INC. INTELLECTUAL PROPERTY RIGHTS, BUSINESS PLANS, CUSTOMERS, AND PRODUCTS THAT ARE CONFIDENTIAL AND OF SUBSTANTIAL VALUE TO FIBERFIN, INC. YOU ARE HEREBY NOTIFIED THAT ANY DISSEMINATION, DISTRIBUTION, OR COPYING OF THIS CONFIDENTIAL INFORMATION WITHOUT PRIOR WRITTEN PERMISSION FROM FIBERFIN, INC. IS STRICTLY PROHIBITED. IN RECEIVING THIS INFORMATION, YOU AGREE THAT YOU SHALL NOT DISCLOSE ANY SUCH CONFIDENTIAL INFORMATION TO ANY THIRD PARTY AND SHALL TAKE EVERY REASONABLE PRECAUTION TO PROTECT SUCH CONFIDENTIAL INFORMATION FROM SUCH DISCLOSURE. IN THE EVENT YOU ARE ASKED TO RETURN THE CONFIDENTIAL INFORMATION TO FIBERFIN, INC., THERE SHALL BE NO USE OR DISCLOSURE BY YOU OF ANY CONFIDENTIAL INFORMATION.

ALL RIGHTS RESERVED BY FIBERFIN, INC.

UNLESS OTHERWISE SPECIFIED:		NAME	DATE
DIMENSIONS ARE IN MILLIMETERS	DRAWN	RH	2/9/2022
	CHECKED		
	ENG APPR.		
	MFG APPR.		
DIMENSIONS BASED UPON ANSI Y 14.5M-1994	Q.A.		
MATERIAL Zinc-Plated Steel	COMMENTS:		
FINISH			
DO NOT SCALE DRAWING			

FiberFin		
9925 State Route 47 Unit A Yorkville, IL 60560 U.S.A.		
TITLE Crimp Ring		
SIZE A	PART NO. FF-LSCRM-P	REV -
SCALE: 10:1	WEIGHT:	SHEET 1 OF 1