

FiberFin LC Connector Cutter Instruction Guide

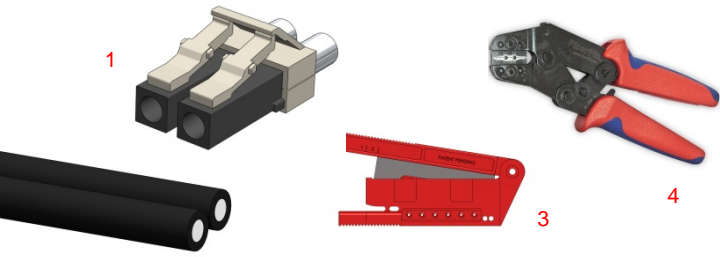

Needed supplies to make a POF cable

- 1) LC Duplex POF connector
- 2) Duplex Zipcord POF Cable
- 3) LC Ultra Low Loss cutter
- 4) LC Duplex Crimp Tool

Work instructions are designed to work with the LC POF Connector Part # FF-LC1000

1. If necessary, use the tool to cut the plastic optical fiber from the cable spool or just finishing the bare cable in slots # 1 as shown in (Figure 1).
2. Split the cable jacket as shown in Figure 2 Insert cable into slot and push down lever, (Figure 2 & 3) remove and separate the zipcord approximately 2"
3. Slide the slit POF cable into the strip hole, Item 4 in Figure 1. You want to strip at least 1" of jacket off the cable.
4. To strip the fiber, insert the fiber into the tool and close the tool. Keep the tool closed then rotate at least 1 1/2 turns (Figure 4) Then pull outward to remove the jacket. (Figure 5)
5. Note: you can only use one hole at a time. There are two holes provided to deal with wear of the blade.

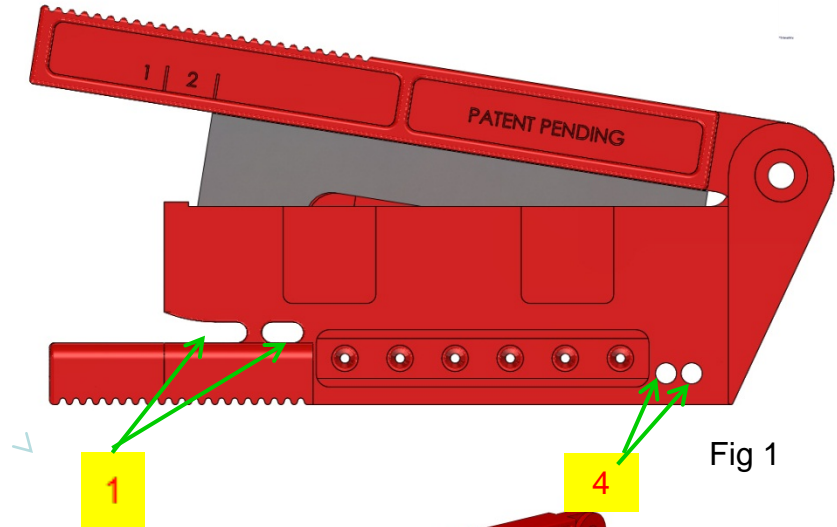

Fig 1

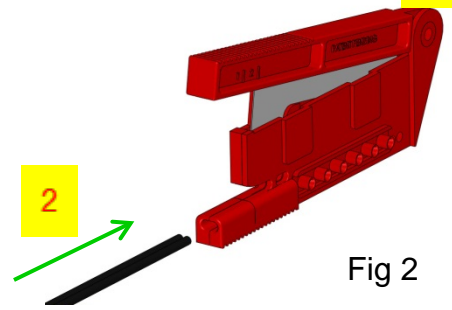

Fig 2

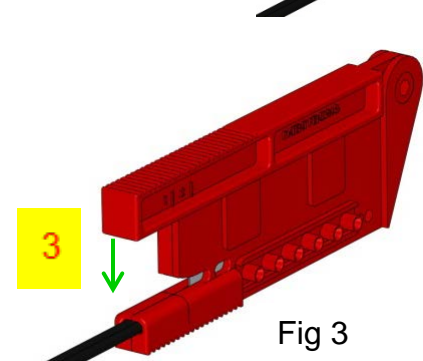

Fig 3

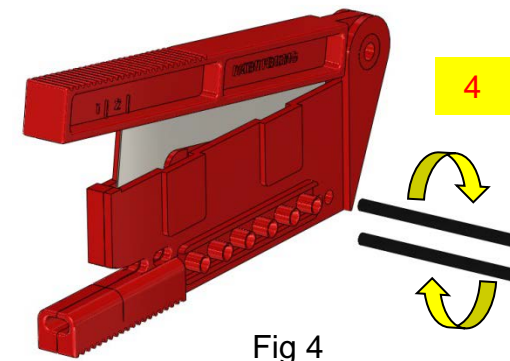

Fig 4

FiberFin LC Connector Cutter Instruction Guide

Work instructions are designed to work with the LC POF Connector Part # FF-LC1000 (Continued)

6. Line up the second fiber to the seam of the tool as shown in Figure 5 and then remove that jacket as well.

7. After stripping the jacket off the fiber's should appear as they do in Figure 6 with 24-27mm of exposed fiber

8. Slide the fiber into the LC connector housing so it bottoms out in the connector Figure 7.

9. To secure the cable within the connector use the crimp tool FF-CRMP-LC (Item 4) on the metal crimp ring,

10. Note: Detail instructions about the LC crimp tool comes with the crimp tool or view details on the FiberFin.com website.

11. After crimping the crimped LC Connector assembly is now ready to be finished, Insert connector into the holes in the front of the tool Figure 8-9

12. The connector should be seated flush as shown in Figure 9.

13. Push in the connector while cutting to insure proper cut position. Figure 9-10-11

(Very Important!)

14. Cleave off the excess fiber using the tool Figure 10 -11 There are 3 sets (6 holes) of locating holes. Each set is good for a maximum of 10 cuts.

15. The final assembly should appear as shown in Figure 12.

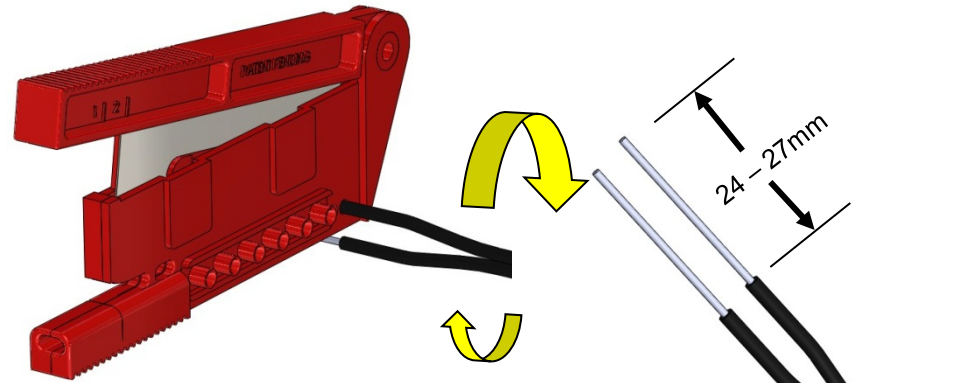

Fig 5

Fig 6

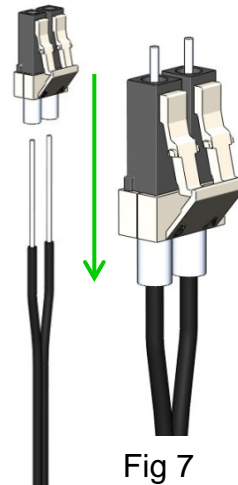

Fig 7

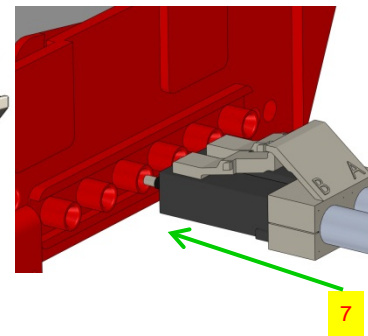

Fig 8

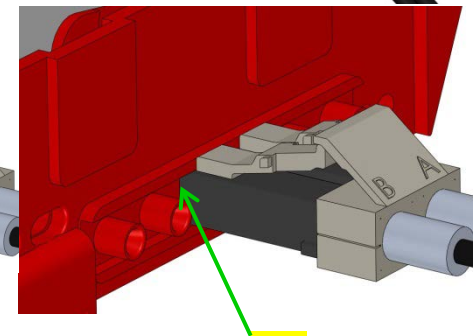

Fig 9

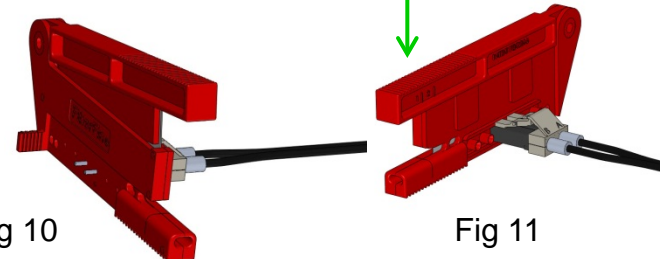

Fig 10

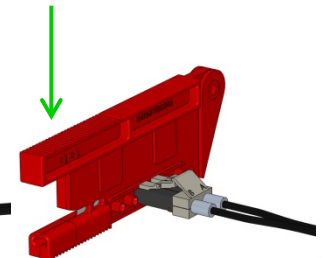

Fig 11

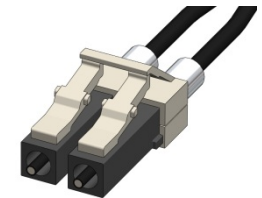

Fig 12